



BAND-IT®
THE CLAMPING EXPERTS

IDEX
IDEX CORPORATION

You Have A Choice!

Center Punch Clamp Production Tool

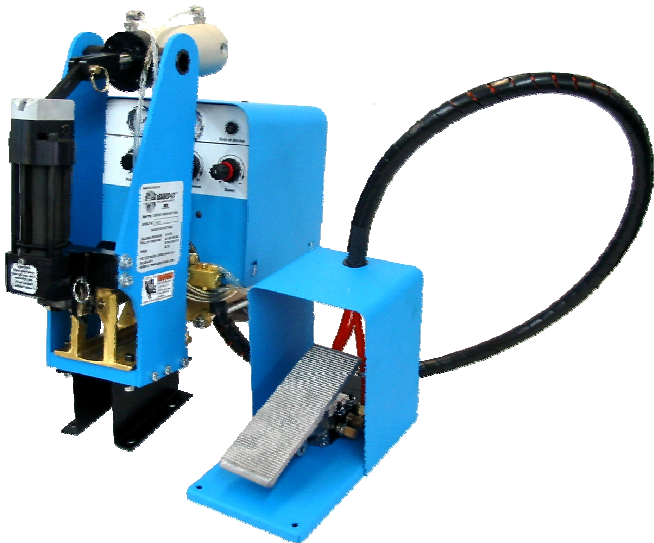

If you clamp 10 or more hoses by hand daily, you should use the SM1700 Center Punch Production Tool!

- Simplifies Center Punch clamp installation
- Reduces hose assembly failures
- Increases productivity

The SM1700 is easy-to-use. The tool installs 5/8" wide Center Punch Clamps from 1" - 8" in diameter.

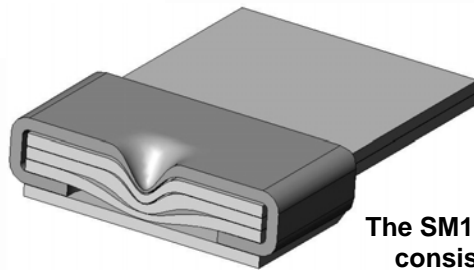

The SM1700's pre-charged gas cylinder produces consistently deep, well formed, strong locks.

SM1700 Features:

One step setup – Our engineers designed this tool to save your valuable time. Adjust the clamp tension and install! Unlike other tools, the pre-charged gas cylinder needs no adjusting for different diameter clamps.

Foot Controlled – Allows both hands to control hose assembly positioning. Your operator can install clamps with greater confidence and safety.

Consistent Lock – The consistency of the depth of the dimple lock maximizes Center Punch clamp strength.

Proven Mechanical Design – Reduces your maintenance and downtime. When support is required, BAND-IT® repairs 99% of tools within three working days.

Portable – Install on a standard work bench or mount on a cart – whichever you prefer. The small size makes it easy and less costly to ship.

Center Punch Clamp Production Tool

Installing BAND-IT® Center Punch Clamps with the SM1700:

1. Choose the correct material type and diameter clamp to best satisfy the needs of the application.
2. Place Center Punch clamps over hose, then install fitting. The buckles of each clamp should be located opposite of each other to increase resistance to leak paths.
3. Insert clamp tail fully into blade assembly with buckle on top.
4. Hold assembly securely with both hands. *Keep fingers and loose clothing away from clamp being applied!*
5. Depress toe end of foot pedal control to tension clamp. Keep toe end down until clamp has been fully tensioned, locked, and cut-off is complete.
6. Depress heel end of foot pedal and retrieve clamp tail from tool head.

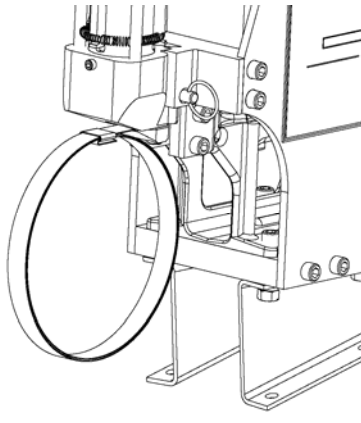

Clamp tail inserted into blade assembly before clamping

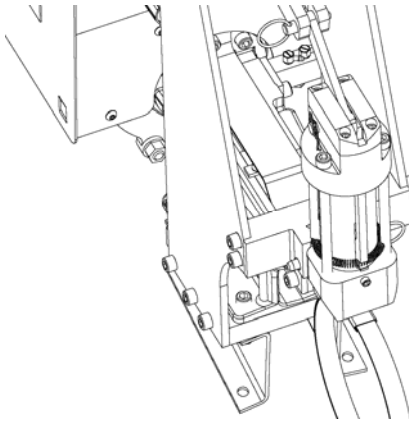

Tool position prior to clamp lock and cut-off

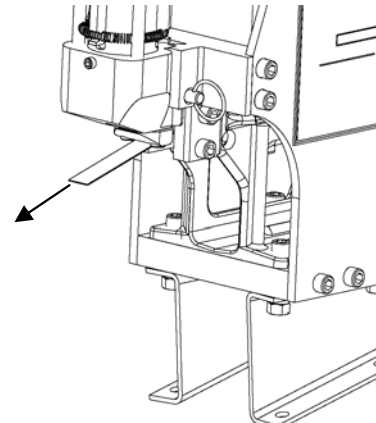

Tool position prior to scrap tail removal

For further product information, download instruction manual at www.band-it-idex.com/products_tools.asp or contact a Product Specialist at 800-525-0758.

WORLD HEADQUARTERS

Denver, CO
Phone: (303) 320-4555
(800) 525-0758
Email: info.BAND-IT@idexcorp.com

EUROPE

Staveley, UK
Phone: (44) 1246-477333
Email: band-itUKinfo.BAND-IT@idexcorp.com

CHINA

Shanghai, China
Phone: 021-62826348 – 308
Email: info.BAND-IT@idexcorp.com



PACIFIC RIM

Singapore, Singapore
Phone: 65-6265-8853
65-6265-8783
Email: info.BAND-IT@idexcorp.com

IDEX
IDEX CORPORATION