



Claw Couplings are a symmetric quick coupling system with two claws each, which are connected by simultaneously applying force and rotating the two claws to be 45° apart.

All connections and sealing systems have the same head dimensions, therefore all types are always interchangeable.

The recommended combination is a standard coupling with a MODY-coupling as the counter part (easy to couple, 100 % tight, absolutely safe).

It is very important to use always couplings made of malleable iron, which is as a result of its special heat treatment suitable for thin-walled parts and which is the only recommended casting material according to DIN 3489 and 3238

Claw Couplings

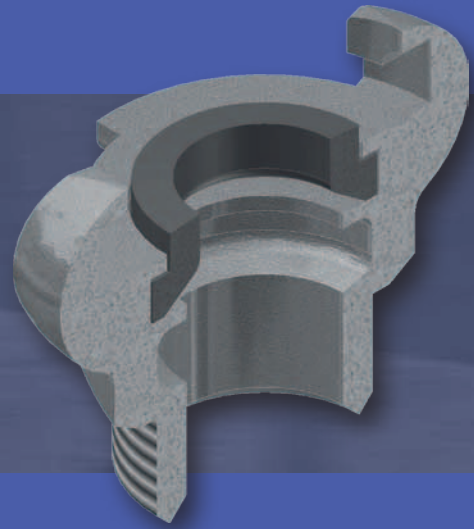

Content

- 21 Swivelling Claw Couplings DIN 3489
- 22 Standard Execution Claw Couplings DIN 3489
- 24 MODY-Screwing Claw Couplings DIN 3238
- 26 The DIN Standards
- 28 Claw Couplings with brass seal
- 29 Claw Couplings with bore for safety clips
- 30 Left-closing and coloured Claw Couplings
- 31 Claw Couplings of hardened steel
- 32 Claw Couplings of stainless steel 1.4401
DIN 3489 and DIN 3238
- 34 Claw Couplings of brass MS 58
- 35 US-Claw Couplings with bore for safety clips

Swivelling Claw Couplings

DIN 3489

New!

- High quality couplings, head of malleable iron, hose stem of turned steel with special profile, zinc plated and yellow passivated (free of chrome VI)
- 360° swivelling, easy turning under pressure, therefore no hose twist
- 2 parts, sealing through 2 O-Rings, swivelling on 2 teflon-discs, safe and protected
- 100 % tight through machined gasket seat, standard rubber ring can be used
- Full bore for increased flow capacity
- On request with steam resistant rubber ring against extra charge of Euro 1.45
- 100 % couple test and sight control
- For flexibility of compressed air lines in construction and industry, if used as thread coupling assembled at the tool up to 10 times higher durability compared to rigid standard couplings! The swivel principle absorbs all vibrations!



Max. Working Pressure	Temperature	Material	Mat. Seals	Norm	Medium	Threads	Claw Distance	⊕
PN 16 bar	-40°C – +95°C	malleable iron / steel	Perbunan	DIN 3489	compressed air	ISO 228	42 mm	5

Hose Claw Couplings Standard Execution

Hose i.D.	DN	b	h	stem Length	Weight/pc. g	Type No.	Euro
1/2" = 13 mm	10	63	87	41	221	SKG 13-DR	9.79
3/4" = 19 mm	15	63	87	41	230	SKG 19-DR	9.79
1" = 25 mm	19	63	87	41	260	SKG 25-DR	9.79

For hose clamps DIN 20039 A type SL (© catalogue page 47) or crimping sockets type LPH (© catalogue page 51)

Hose Claw Couplings with safety collar

Hose i.D.	DN	b	h	∅ collar	stem Length	Weight/pc. g	Type No.	Euro
1/2" = 13 mm	10	63	96	24	41	236	SKB 13-DR	13.02
3/4" = 19 mm	15	63	98	34	41	250	SKB 19-DR	13.02
1" = 25 mm	19	63	98	39	41	290	SKB 25-DR	13.02

For hose clamps DIN 20039 B type SK (© catalogue page 47)

Female Claw Couplings

Thread	DN	b	h	Thread Length	Weight/pc. g	Hexagon	Type No.	Euro
G 1/2"	17	63	61	15	240	24	KIG 12-DR	9.91
G 3/4"	17	63	85	15	330	32	KIG 34-DR	14.02
G 1"	17	63	90	15	430	41	KIG 10-DR	14.02

Male Claw Couplings

Thread	DN	b	h	Thread Length	Weight/pc. g	Hexagon	Type No.	Euro
G 1/2"	13	63	67	14	240	24	KAG 12-DR	9.91
G 3/4"	17	63	68	15	236	24	KAG 34-DR	9.91
G 1"	19	63	83	15	315	36	KAG 10-DR	14.02

Original Rubber Rings

Resistance	Temp.°C	Medium	Material	Colour	Shore hard.	A	∅i	∅a	h	Weight/pc. g	⊕	Type No.	Euro
Oil	-40 – +95	compr. air	Perbunan	black	65°		20	34	11	6 g	100	GOER	0.31
Steam	-40 – +200	steam	Ohasil	nature	60°		20	33	10	6 g	10	GDOR	1.45

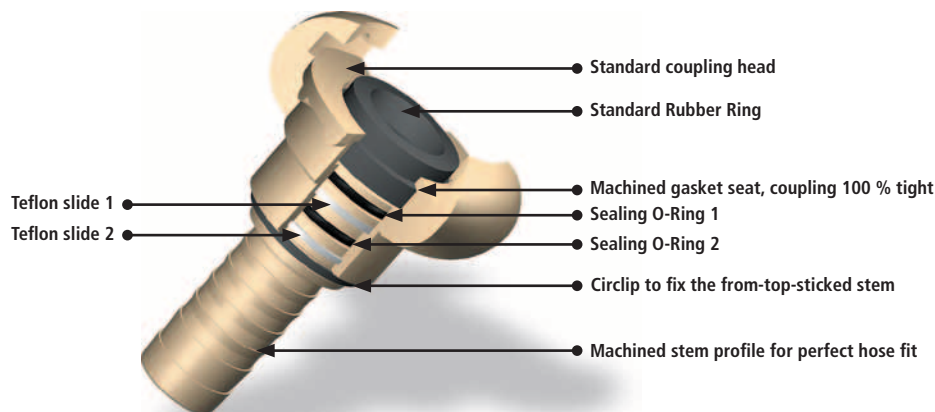
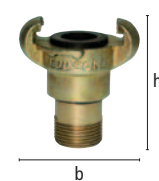

Claw Couplings

Standard Execution DIN 3489

New!

- Robust couplings of malleable iron, zinc plated and yellow passivated (free of chrome VI)
- 100 % couple test and sight control
- With oil-resistant rubber ring GOER, on request with steam-resistant rubber ring GDOR (up to 200°C) against extra charge of Euro 1.45
- Universal coupling, world-wide used system for compressed air in construction and industry



Max. Working Pressure	Temperature	Material	Medium	Claw Distance	Norm	Mat. Seal	Threads	
PN 10 bar	-40°C – +95°C	malleable iron	compressed air	42 mm	DIN 3489	Perbunan	ISO 228	10

Hose Claw Couplings (formerly DIN 3483)

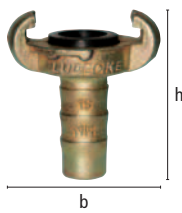

Hose i.D.	DN	b	h	Weight/pc. g	Type No.	Euro
1/4" = 6 mm	5	63	70	157	SKG 6	5.35
3/8" = 10 mm	7	63	76	150	SKG 10	3.56
1/2" = 13 mm	8.5	63	69	141	SKG 13	3.23
5/8" = 15 mm	11	63	69	142	SKG 15	3.45
3/4" = 19 mm	15	63	69	155	SKG 19	3.01
1" = 25 mm	19	63	70	176	SKG 25	3.73
1 1/4" = 32 mm	20	63	90	244	SKG 32	5.23

For hose clamps DIN 20039 A type SL (☺ catalogue page 47) or crimping sockets type LPH (☺ catalogue page 51)

Hose Claw Couplings with safety collar

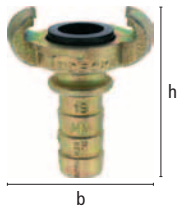

Hose i.D.	DN	b	h	∅ collar	Weight/pc. g	Type No.	Euro
1/2" = 13 mm	8.5	63	75	25	174	SKB 13	3.89
5/8" = 15 mm	11	63	75	26	175	SKB 15	4.01
3/4" = 19 mm	15	63	75	28.5	182	SKB 19	3.17
1" = 25 mm	20	63	75	40	240	SKB 25	4.73

For hose clamps DIN 20039 B, type SK (☺ catalogue page 47), safe hose assembly.

Female Claw Couplings (formerly DIN 3482)

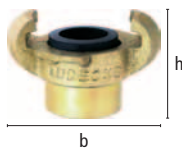
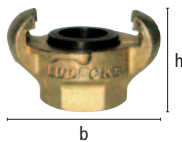

Thread	DN	b	h	∅Hexagon	Weight/pc. g	Type No.	Euro
G 1/4"	11	63	36	22	138	KIG 14	3.95
G 3/8"	15	63	36	22	135	KIG 38	3.95
G 1/2"	19	63	38	27	150	KIG 12	4.11
G 1/2"	19	63	41	-	180	KIGO 12**	4.11
G 3/4"	20	63	40	32	155	KIG 34*	3.28
G 3/4"	20	63	41	-	155	KIGO 34**	3.28
G 1"	20	63	40	41	184	KIG 10*	3.89
G 1 1/4"	20	63	55	50	297	KIG 54	7.67

* against surcharge also available with NPT-Thread

** without Hexagon

Blank Ends (formerly DIN 3484)



Execution	b	h	Weight/pc. g	Type No.	Euro
without chain	63	43	130	VKO	3.11
with chain	63	43	140	VKM	4.34
chain (spare part)			7	VKM-K	1.12

Claw Couplings

Standard Execution DIN 3489



Male Claw Couplings (formerly DIN 3481)

Thread	DN	b	h	Hexagon	Weight/pc. g	Type No.	Euro
G 1/4"	6	63	50	22	157	KAG 14	5.23
G 3/8"	9	63	52	27	170	KAG 38	4.40
G 1/2"	13	63	47	27	162	KAG 12*	4.18
G 3/4"	17	63	50	32	175	KAG 34*	3.89
G 3/4"	17	63	41	-	150	KAGO 34**	4.23
G 1"	20	63	47	40	174	KAG 10*	4.45
G 1"	20	63	41	-	165	KAGO 10**	4.56
G 1 1/4"	20	63	52	46	230	KAG 54	9.29

Easy male thread sealing with PVC-Packing rings type HPD (© below)

* against surcharge also available with NPT-Thread

** without Hexagon, with LÜDSY-sealing ring

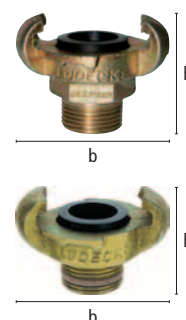

Max. Working Pressure	Temperature	Material	Medium	Threads	Claw Distance	Mat. Seals	⊕
PN 10 bar	-40°C – +95°C	malleable iron	compressed air	DIN 2999	42 mm	Perbunan	1

Three-way connections with threaded ends or claw couplings (rubber seal)

Connection	DN	b	h	Weight/pc. g	Type No.	Euro
3 x R 3/4" f	24	68	68	255	DWS 34	10.90
3 x KAGO 34	17	120	120	708	DWSG 34	25.30
3 x R 1" f	30	85	85	413	DWS 10	18.20
3 x KAGO 10	21	130	135	905	DWSG 10	32.90



Original Rubber Rings for Standard Claw Couplings DIN 3489

Resistance	Material	Temp. °C	Medium	Colour	Shore	h. A	⊘i	⊘a	h	Weight/pc. g	⊕	Type No.	Euro
Oil	Perbunan	-40 – +95	compr. air	black	65°	20	34	11	6	100	GOER	0.31	
Steam	Ohasil	-40 – +200	steam	nature	60°	20	33	10	6	10	GDOR	1.45	
Chemicals	Viton	-40 + 200	chemical	green	60°	20	34	10.5	9	10	GVOR	3.01	



Hard-PVC-Packing Rings for fast, easy and tight sealing of male threads

For male thread	⊘i	⊘a	h	⊕	Weight/pc. g	Type No.	Euro
G 1/8"	10	13	1.5	100	0.13	HPD 18	0.07
G 1/4"	13.3	16.4	2	100	0.31	HPD 14	0.08
G 3/8"	16.7	21.5	2	100	0.37	HPD 38	0.11
G 1/2"	21.5	26	2	100	0.53	HPD 12	0.11
G 3/4"	26.5	31.4	2	100	0.73	HPD 34	0.13
G 1"	33.5	40	2	100	1.15	HPD 10	0.24



Claw Couplings

MODY-Screwing Couplings DIN 3238

- High quality safety coupling, head of malleable iron, hose stem of turned steel with special profile, zinc plated and yellow passivated (free of chrome VI)
- Stronger thread - protective ring and new rubber ring, on both sides led in gasket seat
- With oil resistant rubber ring, on request with steam resistant rubber ring (up to 200°C), against extra charge of Euro 1.45
- 100 % tight, reduces expensive air consumption
- Easy to couple, secured against accidental opening, just screw ring after coupling!
- 100 % couple test and sight control
- Maximum bore for more flow capacity
- For absolutely safe air lines in construction and industry

New!



Max. Working Pressure	Temperature	Material	Mat. Seal	Medium	DIN	Threads	Claw Distance	⊕
PN 16 bar	-40°C – +95°C	mall. iron / steel	Perbunan	compr. air	DIN 3238	ISO 228	42 mm	5

MODY-Hose Couplings Standard execution

Hose i.D.	DN	b	h	Weight/pc. g	Type No.	Euro
3/8" = 10 mm	6.5	63	100	309	SSG 10	10.46
1/2" = 13 mm	10	63	100	309	SSG 13	10.46
5/8" = 15 mm	11	63	100	316	SSG 15	10.46
3/4" = 19 mm	15	63	100	319	SSG 19	10.46
1" = 25 mm	18	63	100	346	SSG 25	10.46
1 1/4" = 32 mm	18	63	135	464	SSG 32	15.81

For hose clamps DIN 20039 A type SL (⊕ catalogue page 47) or crimping sockets type LPH (⊕ catalogue page 51)



MODY-Hose Couplings with safety collar

Hose i.D.	DN	∅collar	b	h	Weight/pc. g	Type No.	Euro
3/8" = 10 mm	6.5	21	63	103	323	SSG 10 S	13.91
1/2" = 13 mm	10	24	63	110	321	SSG 13 S	13.91
5/8" = 15 mm	11	27	63	112	343	SSG 15 S	13.91
3/4" = 19 mm	15	32	63	112	350	SSG 19 S	13.91
1" = 25 mm	18	39	63	112	386	SSG 25 S	13.91

For hose clamps DIN 20039 B type SK (⊕ catalogue page 47)



MODY-Hose Couplings for crimping sockets (hydraulic crimping)

Hose i.D.	DN	∅collar	b	h	Weight/pc. g	Type No.	Euro
3/4" = 19 mm	15	24	63	108	359	SSG 19 PH	12.13

Crimping with crimping socket PH-19 (⊕ catalogue page 59)

Other sizes on request



MODY-Hose Couplings for Aluminium forged clamps

Hose i.D.	DN	∅collar	b	h	Weight/pc. g	Type No.	Euro
3/4" = 19 mm	15	26	63	110	340	SSG 19-KSA	12.69

For aluminium forged clamps VG 85 328 type KSA 30-33 (⊕ catalogue page 71)



MODY-Hose Couplings with brass safety clamp for steam applications

For Hose	DN	Mat. sealing ring	b	h	Weight/pc. g	Type No.	Euro
13 x 6 (1/2")	10	Ohasil (SDOR-N)	63	113	820	SSG 13 KSM	30.31
19 x 7 (3/4")	15	Ohasil (SDOR-N)	63	113	920	SSG 19 KSM	30.31
25 x 7.5 (1")	18	Ohasil (SDOR-N)	63	113	1120	SSG 25 KSM	41.60



Claw Couplings MODY-Screwing Couplings DIN 3238

New!

- Thread ferrule according to DIN EN 14 424 as the perfect hose connection for optimum security; at any time unlockable and reusable.

Please pay attention to the details for the essential hose wall thickness!

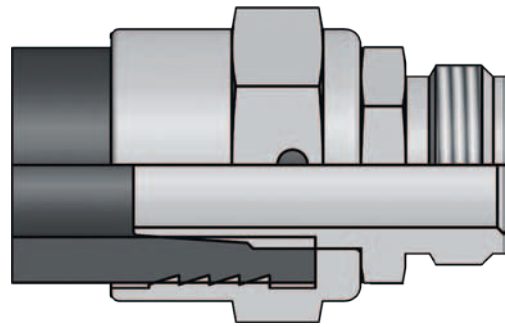

MODY-Hose Couplings with thread ferrule (according to DIN EN 14 424)

Hose Dimension	DN	b	h	⊘ferrule	Weight/pc. g	Type No.	Euro
1/2" = 13 x 3	11	63	92	27	400	SSG 133 TQ	16.48
1/2" = 13 x 5	11	63	92	27	405	SSG 135 TQ	16.48
5/8" = 15 x 5	13	63	95	32	415	SSG 155 TQ	17.36
3/4" = 19 x 5	16	63	95	32	435	SSG 195 TQ	17.36
3/4" = 19 x 6	16	63	95	36	440	SSG 196 TQ	17.36
1" = 25 x 5	22	63	105	41	510	SSG 255 TQ	21.26
1" = 25 x 7	22	63	105	46	520	SSG 257 TQ	21.26

(Size 1" two parts screwed)

Assembly instructions for thread ferrules (© catalogue page 182)



New!

MODY-female Couplings

Thread	DN	b	h	⊘Hexagon	Weight/pc. g	Type No.	Euro
G 3/8"	13	63	68	24	347	SSGI 38	12.92
G 1/2"	17	63	70	24	329	SSGI 12	12.92
G 3/4"	17	63	93	32	419	SSGI 34	15.02
G 1"	17	63	95	41	516	SSGI 10	15.91

On request also available with NPT thread against extra charge

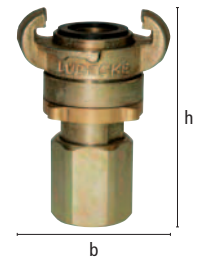

MODY-Male Couplings with LÜDSY-sealing system

Thread	DN	b	h	⊘Hexagon	Weight/pc. g	Type No.	Euro
G 3/8"	10	63	72	24	320	SSGA 38	13.57
G 1/2"	13	63	73	24	351	SSGA 12	13.57
G 3/4"	17	63	73	24	345	SSGA 34	13.57
R 1"	17	63	85	36	401	SSGA 10	16.14

On request also available with NPT thread against extra charge

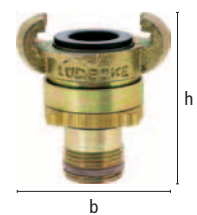

Original MODY-Rubber Rings – Standard Execution

Resistance	Material	Temp.°C	Medium	Colour	Shore	h. A	⊘i	⊘a	h	Weight/pc. g	⊠	Type No.	Euro
Oil	Perbunan	-40 – +95	compr. air	black	75°	21	30	4	1.7	100	100	SGOR-N	0.33
Steam	Ohasil	-40 – +200	steam	nature	75°	21	30	4	1.7	10	10	SDOR-N	1.85



Original MODY-Rubber Rings – Old Execution (Only suitable for MODY-Couplings with old gasket seat!)

Resistance	Material	Temp.°C	Medium	Colour	Shore	h. A	⊘i	⊘a	h	Weight/pc. g	⊠	Type No.	Euro
Oil	Perbunan	-40 – +95	compr. air	black	60°	21	33	7	4	100	100	SGOR	0.45
Steam	Ohasil	-40 – +200	steam	nature	70°	21	33	7	3.5	10	10	SDOR	2.35



All Types also available coloured (powder-coated) against extra charge of Euro 3.50/pc.

RAL 5010
 RAL 6029
 RAL 1004
 RAL 2002
 ...Others on request

⊠ Attention: At least 100 pc/type necessary!



LUDECKE – Information regarding the new Standards

In exchange for DIN 3238-1, 3238-2 now exists only

DIN
3238 R2,5

This Standard covers:

MODY-Screwing Couplings made of malleable iron / steel:

Sealing rings



MODY-Screwing Couplings made of stainless steel

Sealing ring



EKS



SVOR-N

New sealing ring, lead on both sides in new gasket seat

DIN
3238

Special requirements

- Threads according to **DIN-ISO 228/1**
- Claw couplings and sealing rings corresponding to this standard **have to be marked with manufacturers name!**
- Working pressure **max. 16 bar**
- **100 % sight control** required
- **100 % couple test** with test gauge required.
- **Certified material:**
Malleable Iron: EN-GJMW-400-5(EN-JM1030) according to DIN EN 1562
M1-Alloy: Alloy DIN 17660-CuZn39Pb2 (2.0380)
Steel: Type to be chosen by manufacturers 11SMnPb30 (1.0718) according to DIN EN 10087 · 11SMnPb30 (1.0718) according to DIN EN 10277-3
X5CrNi Mo 17-12-2 (1.4401) according to DIN EN 10088-1 · G-X5CrNiMo 19-11-2 (1.4408) according to DIN EN 10213-4
G-X5CrNiMoNb 19-11-12 (1.4581) according to DIN EN 10213-4
- New claw dimensions
- New sealing ring
- New gasket seat to lead sealing ring on both sides

Warning!

Compressed air can be a dangerous medium that requires strict safety rules while handling which have to be observed to avoid serious accidents. Today on the coupling market asian low-price copies often appear, made of low-grade and not certified material, in most cases inferior casted and machined. The use of these couplings hides an uncalculable safety risk. No secure hose fit can be guaranteed, as a result of big

tolerances a lot of these couplings are very hard to couple or even can not be coupled, threads are not true to gauge. Very often claws, thread ends and gasket seats are melted out, claw distances are too big or have offset lugs. Moreover these couplings are mainly casted in too hard material and therefore brake under heavy strain. Sealing rings often are not oil resistant.



These couplings appear to be a substantial safety risk and should not be used!
They do not at all correspond to the DIN Standards!

LUDECKE – Information regarding the new Standards

In exchange for DIN 3481 / 3482 / 3483 / 3484 / 3485 now exists only

DIN
3489

This Standard covers:

Standard Claw Couplings made of malleable iron



KAG



KIG



SKG



VKO



GDOR

GOER



Swivelling Claw Couplings made of malleable iron / steel



KAG-DR



KIG-DR



SKG-DR

Standard Claw Couplings made of stainless steel



EKA



EKI



EKT

Sealing ring



GVOR

DIN
3489

Special requirements

- Threads according to **DIN ISO 228/2**
- Claw couplings and sealing rings corresponding to this standard **have to be marked with manufacturers name!**
- Working pressure **max. 10 bar**
- **100 % sight control** required
- **100 % couple test** with test gauge required.
- **Certified material:**
Malleable Iron: EN-GJMW-400-5(EN-JM1030) according to DIN EN 1562
M1-Alloy: Alloy DIN 17660-CuZn39Pb2 (2.0380)
Steel: Type to be chosen by manufacturer
11SMnPb30 (1.0718) according to DIN EN 10087
11SMnPb30 (1.0718) according to DIN EN 10277-3
X5CrNi Mo 17-12-2 (1.4401) according to DIN EN 10088-1
G-X5CrNiMo 19-11-2 (1.4408) according to DIN EN 10213-4
G-X5CrNiMoNb 19-11-12 (1.4581) according to DIN EN 10213-4
- New claw dimensions

Test gauge for claw couplings

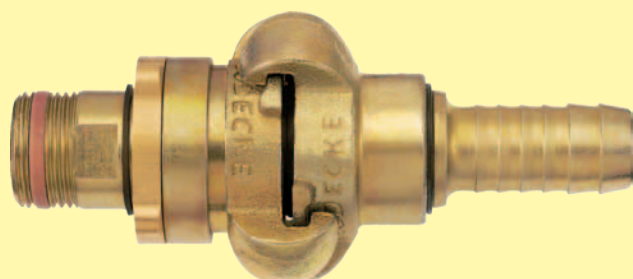
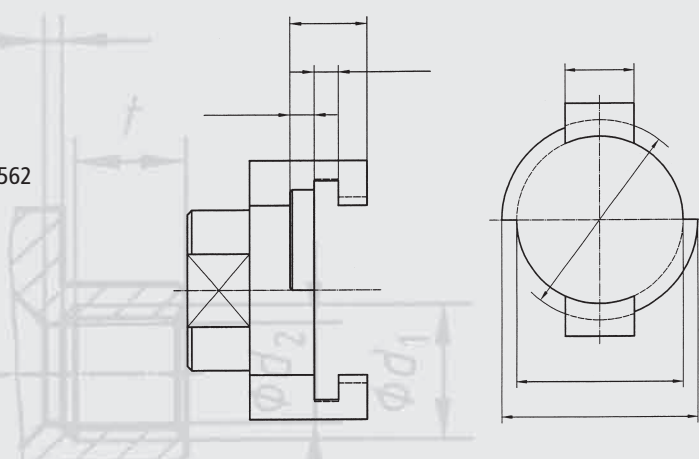

We always recommend to use a standard coupling according to DIN 3489 and as the counter coupling a mody screwing coupling according to DIN 3238. This connection is absolutely safe, easy to couple, 100 % tight and secured against unintentional opening. Also for safe hose assembly always use clamps according to DIN 20039. Malleable Iron according to DIN EN 1562 avoids as a result of its toughness and flexibility breaking of the couplings under heavy strain. These characteristics are essential e.g. for the use directly on compressed air hammers and therefore malleable iron is according to DIN 3489 and DIN 3238 the exclusive casting material for claw couplings.

Claw Couplings

with brass seal

New!

- Robust couplings of malleable iron, zinc plated and yellow passivated (free of chrome VI)
- 100 % couple test and sight control
- With brass seal, oil-resistant hose ring and zinc plated screw
- Easy to couple, no independent remove of the seal
- Always to be coupled with a standard claw coupling with Perbunan seal!
- **Universal couplings for air lines in construction or industry, mainly used directly on compressor or air tool**



Max. Working Pressure	Temperature	Material	Medium	Claw Distance	Mat. Seal	Threads	⊞
PN 10 bar	-40°C – +95°C	malleable iron	compressed air	42 mm	Brass / Perbunan	ISO 228	10

Hose Claw Couplings with brass seal



Hose i.D.	DN	b	h	Weight/pc. g	Type No.	Euro
1/2" = 13 mm	8.5	63	78	212	SKM 13*	9.40
5/8" = 15 mm	11	63	88	226	SKM 15*	9.80
3/4" = 19 mm	15	63	84	211	SKM 19	5.45
1" = 25 mm	19	63	84	225	SKM 25	6.90

For hose clamps type SL DIN 20039 A (© catalogue page 47)

*two parts with thread stem of steel

Female Claw Couplings with brass seal

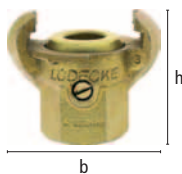

Thread	DN	b	h	⊞Hexagon	Weight/pc. g	Type No.	Euro
G 1/2"	17	63	48	27	181	KIM 12	8.20
G 3/4"	17	63	50	32	200	KIM 34	6.30
G 1"	17	63	52	41	260	KIM 10	8.60

Male Claw Couplings with brass seal



Thread	DN	b	h	⊞Hexagon	Weight/pc. g	Type No.	Euro
G 1/2"	11	63	55	27	193	KAM 12	9.60
G 3/4"	17	63	51	32	206	KAM 34	7.24
G 1"	17	63	48	40	213	KAM 10	8.12

Easy male thread sealing with PVC-Packing rings type HPD (© catalogue page 23)

Original spare parts brass seal



Type	∅i	∅a	h	Weight/pc. g	⊞	Type No.	Euro
Brass sleeve	17	32	21	12.5	100	MOOH	1.60
Perbunan hose ring	23	28	12	3.2	100	SOOR	0.45
Steel screw M5	-	7	14	2	100	HOOS	0.40

Claw Couplings with bore for safety-clips

New!

- Robust couplings of malleable iron, zinc plated and yellow passivated (free of chrome VI)
- 100 % couple-test and sight control
- With oil-resistant rubber ring GOER, on request with steam-resistant rubber ring GDOR (up to 200°C) against extra charge Euro 1.45
- To be secured against accidental opening through safety-clips DIN 11024
- Universal coupling, mainly used worldwide in mining or tunneling



Max. Working Pressure	Temperature	Material	Medium	Claw Distance	Mat. Seal	Threads	⊠
PN 10 bar	-40°C – +95°C	malleable iron	compressed air	42 mm	Perbunan	ISO 228	10

Hose Claw Couplings with safety collar

Hose i.D.	DN	b	h	Weight/pc. g	Type No.	Euro
1/2" = 13 mm	8.5	63	74	167	SKSS 13	4.01
3/4" = 19 mm	15	63	75	196	SKSS 19	3.98
1" = 25 mm	19	63	75	222	SKSS 25	4.84

For hose clamps DIN 20039 B, type SK (⊗ catalogue page 47), safe hose assembly

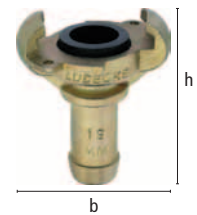

Female Claw Couplings

Thread	DN	b	h	⊠Hexagon	Weight/pc. g	Type No.	Euro
G 1/2"	18.5	63	37	27	141	KISS 12	4.28
G 3/4"	20	63	39	32	145	KISS 34	4.06
G 1"	20	63	41	41	182	KISS 10	5.40

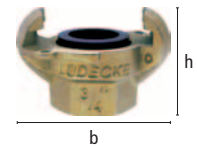

Male Claw Couplings

Thread	DN	b	h	⊠Hexagon	Weight/pc. g	Type No.	Euro
G 1/2"	13	63	49	27	170	KASS 12	4.84
G 3/4"	17	63	49	32	182	KASS 34	4.68
G 1"	20	63	53	39	199	KASS 10	4.95

Easy male thread sealing with PVC-Packing rings type HPD (⊗ catalogue page 23)

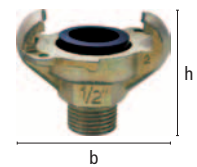

Original Rubber Rings

Resistance	Temp.°C	Medium	Material	Colour	Shore	h. A	⊘i	⊘a	h	Weight/pc. g	⊠	Type No.	Euro
Oil	-40 – +95	compr. air	Perbunan	black	65°	20	34	11	6	100	GOER	0.31	
Steam	-40 – +200	steam	Ohasil	nature	60°	20	33	10	6	10	GDOR	1.45	



Universal Safety-Clips DIN 11024

Material	Wire ⊘	b	h	Weight/pc. g	⊠	Type No.	Euro
Steel zinc plated	3 mm	63	27	10	50 St.	USC-1	0.35



Claw Couplings

Left-closing and coloured

New!

- Robust couplings of malleable iron resp. steel, zinc plated and yellow passivated (free of chrome VI)
- 100 % couple-test and sight control
- With oil-resistant rubber ring SGOR-N, on request with steam-resistant rubber ring SDOR-N (up to 200°C) or with brass seal
- Through left-closing mechanism the couplings can't be connected with standard claw couplings (right-closing), additional warning through ears at the claws or colour
- **Mainly used in chemical and petrochemical plants to avoid connection of different fluids, e.g. compressed air, steam, gas medias, nitrogen...**



Max. Working Pressure	Temperature	Material	Medium	Claw Distance	Mat. Seal	Threads	
PN 10 bar / 16 bar	-40°C – +95°C	malleable iron / steel	various	42 mm	brass / Perbunan	ISO 228	1

Hose Claw Couplings left-closing

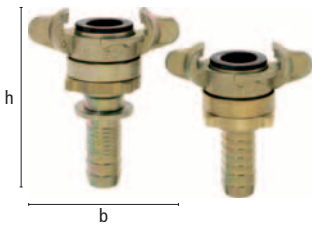

Hose i.D.	DN	Type	b	h	Safety collar	Weight/pc. g	Mat. Seal	Type No.	Euro
3/4" = 19 mm	16	MODY	85	100	without	340	Perbunan	SSGL 19	14.24
3/4" = 19 mm	16	MODY	85	112	with	367	Perbunan	SSGL 19 S	17.36
3/4" = 19 mm	16	brass seal	85	84	without	240	Brass	SKML 19	7.90

Other sizes on request.

For hose clamps DIN 20039 A resp. B (© catalogue page 47)

Female Claw Couplings left-closing



Thread	DN	Type	b	h	Hexagon	Weight/pc. g	Mat. Seal	Type No.	Euro
G 3/4" f	17	brass seal	85	50	32	130	Brass	KIML 34	8.68
G 3/4" f	19	MODY	85	93	32	434	Perbunan	SSGIL 34	18.25

Other sizes on request.

Male Claw Couplings left-closing



Thread	DN	Type	b	h	Hexagon	Weight/pc. g	Mat. Seal	Type No.	Euro
G 3/4" m	19	MODY	85	73	24	339	Perbunan	SSGAL 34	17.14

Other sizes on request.

Original MODY-Rubber Rings – Standard Execution

(© catalogue page 25)

Original MODY-Rubber Rings – Old Execution

(© catalogue page 25)

Original Spare Parts Brass Seal



Type	Øi	Øa	h	weight/pc. g		Type No.	Euro
Brass sleeve	17	32	21	12.5	100	MOOH	1.60
Perbunan hose ring	23	28	12	3.2	100	SOOR	0.45
Steel screw M5	-	7	14	2	100	HOOS	0.40

All types also available coloured (powder-coated) against extra charge of Euro 3.50/pc.!

RAL 5010
 RAL 6029
 RAL 1004
 RAL 2002
 ...others on request.

Ⓜ Attention: At least 100 pc/type necessary!



Claw Couplings

of forged steel, hardened

- Extreme robust, durable coupling of forged steel, hardened, zinc plated and yellow passivated (free of chrome VI), equivalent to type Atlas Copco **New!**
- With oil-resistant rubber ring GOER, on request with steam-resistant rubber ring GDOR (up to 200°C) against extra charge of Euro 1.45
- Maximum bore for maximum flow capacity to reach full tool performance
- Turned gasket seat, therefore 100 % tight
- Turned stem profile for perfect fit of the hose
- High Quality coupling for compressed air in construction and industry



Max. Working Pressure	Temperature	Material	Medium	Claw Distance	Mat. Seal	Threads	⊠
PN 10 bar / 16 bar	-40°C – +95°C	steel hardened	compressed air	42 mm	Perbunan	ISO 228	10

Hose Claw Couplings

Hose i.D.	DN	b	h	Weight/pc. g	Type No.	Euro
1/4" = 6.3 mm	5	62	58	122	ACK 14 T	9.68
3/8" = 10 mm	8	62	63	141	ACK 38 T	9.68
1/2" = 12.5 mm	10.5	62	63	136	ACK 12 T	9.68
5/8" = 16 mm	13.5	62	65	144	ACK 58 T	9.68
3/4" = 20 mm	17	62	70	165	ACK 34 T	9.68
1" = 25 mm	20	62	73	173	ACK 10 T	9.68

For hose clamps DIN 20039 A, type SL (© catalogue page 47)

Swivelling execution (against hose twist) on request.

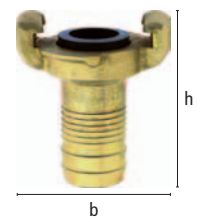

Female Claw Couplings*

Thread	DN	b	h	Weight/pc. g	Type No.	Euro
G 3/8"	15	62	40	182	ACK 38 I	9.79
G 1/2"	19	62	40	203	ACK 12 I	9.79
G 5/8"	19	62	40	194	ACK 58 I	9.79
G 3/4"	20	62	40	176	ACK 34 I	9.79
G 1"	20	62	40	160	ACK 10 I	9.79

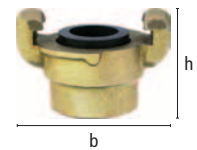

Male Claw Couplings*

Thread	DN	b	h	Weight/pc. g	Type No.	Euro
G 3/8"	11	62	40	142	ACK 38 A	9.79
G 1/2"	15	62	40	152	ACK 12 A	9.79
G 5/8"	16	62	40	148	ACK 58 A	9.79
G 3/4"	19	62	40	148	ACK 34 A	9.79
G 1"	20	62	40	152	ACK 10 A	9.79

Easy male thread sealing with PVC-Packing rings type HPD (© catalogue page 23)

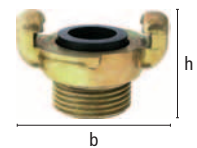

Blank Ends

Execution	b	h	Weight/pc. g	Type No.	Euro
without chain	62	40	140	ACKO	10.58
with chain	62	40	150	ACKM	11.80
chain (spare part)			7	VKM-K	1.12

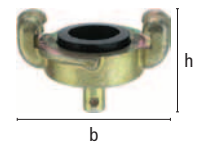

Original Rubber Rings

(© catalogue page 23)

MODY-Hose Couplings with thread-protective ring and new sealing-ring, on both sides led in gasket seat.

Hose i.D.	DN	b	h	Weight/pc. g	⊠	Type No.	Euro
1/2" = 12.5 mm	10	62	92	321	5	ACS 13	23.04
3/4" = 20 mm	17	62	92	331	5	ACS 19	23.04
1" = 25 mm	19	62	92	356	5	ACS 25	23.04

For hose clamps DIN 20039 A, type SL (© catalogue page 47)

*On request also available with NPT thread against extra charge



New!

Original Rubber Rings for MODY-Screwing Couplings – Standard Execution

(© catalogue page 25)

Original Rubber Rings for MODY-Screwing Couplings – Old Execution

(© catalogue page 25)

Claw Couplings DIN 3489 / DIN 3238

of stainless steel 1.4401

- High quality couplings of rust- and acid-resistant steel 1.4401
- With acid-resistant rubber ring of viton (caoutchuc), other materials ☺ below
- Couplings investment casted, perfect surface finish
- Maximum bore for maximum flow capacity
- Turned gasket seat, therefore 100 % tight
- Turned stem profile for perfect fit of the hose
- 100 % couple-test and sight control
- For aggressive fluids (according to concentration) in chemical- or petrochemical industry, in tank- or container-construction. For food- or drinking-water applications use rubber ring type GPOR resp. SPOR-N



Max. Working Pressure	Temperature	Material	Medium	Claw Distance	Mat. Seal	Threads	☺
PN 16 bar	-30°C – +200°C	1.4401	chemical medias	42 mm	Viton	ISO 228	1

Hose Claw Couplings DIN 3489

Hose i.D.	DN	b	h	Weight/pc. g	Type No.	Euro
3/8" = 10 mm	6.5	63	65	125	EKT 10 V	34.16
1/2" = 13 mm	9	63	65	129	EKT 13 V	34.16
3/4" = 19 mm	15	63	65	142	EKT 19 V	34.16
1" = 25 mm	20	63	65	165	EKT 25 V	34.16

Swivelling execution on request.

Female Claw Couplings DIN 3489

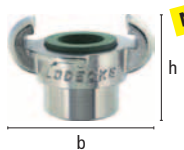

New!

Thread	DN	b	h	Weight/pc. g	Type No.	Euro
G 3/8"	15	63	41.5	173	EKI 38 V	33.61
G 1/2"	19	63	41.5	163	EKI 12 V	33.61
G 3/4"	20	63	41.5	158	EKI 34 V	33.61
G 1"	20	63	41.5	160	EKI 10 V	33.61

On request also available with NPT thread against extra charge!

Male Claw Couplings DIN 3489 with thread protective cap

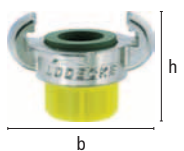

Thread	DN	b	h	Weight/pc. g	Type No.	Euro
G 3/8"	10	63	39	148	EKA 38 V	33.61
G 1/2"	14	63	39	151	EKA 12 V	33.61
G 3/4"	19	63	41.5	155	EKA 34 V	33.61
G 1"	20	63	41.5	180	EKA 10 V	33.61

On request also available with NPT thread against extra charge!

Blank Ends DIN 3489



Execution	b	h	Material	Weight/pc. g	☺	Type No.	Euro
without chain	63	42		144		EKO V	30.16
with chain	63	42		136		EKM V	32.50
chain (spare part)			1.4301	7	10	EKMV-K	2.12



New!

Original Rubber Ring DIN 3489

Resistance	Temp.°C	Material	Colour	Shore h. A	Øi	Øa	h	Weight/pc. g	☺	Type No.	Euro
chem. medias	-30 /+200	Viton	green	50°	20	34	10.5	9	10	GVOR	3.01
Steam	-40 /+200	Ohasil	nature	60°	20	33	10	6	10	GDOR	1.45
foods	-40 /+130	EPDM	nature	70°	20	34	10.5	9	10	GPOR	2.89

- Free of dead space hose assembly for optimum safety- and hygiene-standard, no dirt nests!
- Please note correct hose dimensions!



New!



Hose Claw Couplings with thread ferrule (according to DIN EN 14 424)

Hose Dimension	DN	b	h	Weight/pc. g	Type No.	Euro
1/2" = 13 x 3	11	63	57	170	EKTQ 133 V	40.96
1/2" = 13 x 5	11	63	57	175	EKTQ 135 V	40.96
5/8" = 15 x 5	13	63	57	190	EKTQ 155 V	42.52
3/4" = 19 x 5	16	63	57	195	EKTQ 195 V	42.52
3/4" = 19 x 6	16	63	57	200	EKTQ 196 V	42.52
1" = 25 x 5	22	63	62	250	EKTQ 255 V	44.41
1" = 25 x 7	22	63	62	260	EKTQ 257 V	44.41

(Thread ferrule brass chromed).

Assembly instructions for thread ferrules (© catalogue page 182).

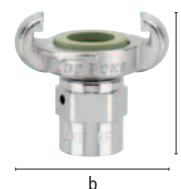

Mody-Hose Claw Couplings DIN 3238

Hose i.D.	DN	b	h	Weight/pc. g	Type No.	Euro
1/2" = 13 mm	9	63	105	337	EKS 13 V	62.66
3/4" = 19 mm	15	63	105	350	EKS 19 V	62.66
1" = 25 mm	18	63	105	380	EKS 25 V	62.66

Other sizes on request.



Mody-Hose Claw Couplings with brass safety clamp for steam applications

For Hose	DN	Mat. sealing	b	h	Weight/pc. g	Type No.	Euro
13 x 6 (1/2")	10	Ohasil (SDOR-N)	63	120	840	EKS 13 KSM	79.40
19 x 7 (3/4")	15	Ohasil (SDOR-N)	63	120	940	EKS 19 KSM	82.20

For Hose 25 x 7,5 (1") on request



Mody-Male Thread Claw Couplings DIN 3238 with new gasket seat

Thread	DN	b	h	Weight/pc. g	Type No.	Euro
G 1/2"	13	63	77	320	EKSA 12 V	62.66
G 3/4"	18	63	80	335	EKSA 34 V	62.66
G 1"	18	63	82	370	EKSA 10 V	62.66

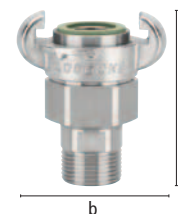

Mody-Female Thread Claw Couplings DIN 3238

Thread	DN	b	h	Weight/pc. g	Type No.	Euro
G 1/2"	18	63	80	345	EKSI 12 V	62.66
G 3/4"	18	63	95	430	EKSI 34 V	67.50
G 1"	18	63	100	530	EKSI 10 V	67.50



Original Rubber Ring for MODY-Claw Couplings DIN 3238

Execution	Resistance	Temp. °C	Material	Color	Hardness	Øi	Øa	h	Weight/pc. g	⊠	Type No.	Euro
DIN 3238	chem. medias	-30 / +200	Viton	green	60°	21	30	4	2	10	SVOR-N	3.23
OLD	chem. medias	-30 / +200	Viton	green	60°	21	32,5	7	5	10	SVOR	3.89
DIN 3238	steam	-40 / +200	Ohasil	nature	75°	21	30	4	2	10	SDOR-N	1.45
DIN 3238	foods	-40 / +130	EPDM	nature	75°	21	30	4	2	10	SPOR-N	2.67



Claw Couplings

of forged brass MS 58

- Universal couplings of forged brass MS 58
- With oil-resistant rubber ring MK 42 ER
- Turned gasket seat, therefore 100 % tight
- For compressed air and water in construction, agriculture and industry



Max. Working Pressure	Temperature	Material	Medium	Claw Distance	Mat. Seal	Thread	
PN 10 bar	-40°C – +95°C	brass MS 58	compressed air	42 mm	Perbunan	ISO 228	10

Hose Claw Couplings

Hose i.D.	DN	b	h	Weight/pc. g	Type No.	Euro
1/4" = 7 mm	6	57	76	115	MKS 42-6	6.63
3/8" = 10 mm	8	57	69	120	MKS 42-10	5.78
1/2" = 13 mm	10	57	69	130	MKS 42-13	5.27
5/8" = 16 mm	12	57	69	131	MKS 42-15	5.27
3/4" = 19 mm	15	57	69	155	MKS 42-19	5.54
1" = 25 mm	21	57	69	180	MKS 42-25	6.46

For hose clamps/clips type SL, type HS, ZOS, LPH(© catalogue page 47–50)

Female Claw Couplings

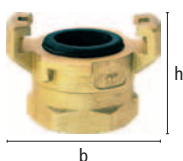

Thread	DN	b	h	Weight/pc. g	Type No.	Euro
G 1/4"	8	17	57 38	93	MKI 42-14	4.25
G 3/8"	12	21	57 33	97	MKI 42-38	4.25
G 1/2"	15	26	57 33	101	MKI 42-12	4.25
G 3/4"	21	32	57 36	119	MKI 42-34	4.59
G 1"	21	39	57 38	124	MKI 42-10	5.27
G 1 1/4"	21	47	57 43	166	MKI 42-54	6.46

Male Claw Couplings

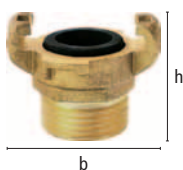

Thread	DN	b	h	Weight/pc. g	Type No.	Euro
G 1/4"	7	17	57 43	104	MKA 42-14	4.42
G 3/8"	10	21	57 45	102	MKA 42-38	4.42
G 1/2"	14	24	57 42	112	MKA 42-12	4.35
G 3/4"	19	30	57 43	135	MKA 42-34	4.68
G 1"	21	34	57 43	140	MKA 42-10	5.10
G 1 1/4"	21	44	57 46	193	MKA 42-54	7.57

Easy male thread sealing with PVC-Packing rings type HPD (© catalogue page 23)

Blank Ends

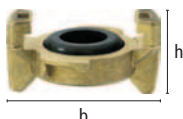

Execution	b	h	Weight/pc. g	Type No.	Euro
without chain	57	29	93	MKO 42	4.25

Original Rubber Ring

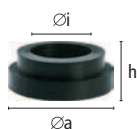

Resistance	Temp. °C	Material	Medium	Colour	Shore	h. A	Øi	Øa	h	Weight/pc. g	Type No.	Euro
Oil	-40 – +95	Perbunan	air/water	black	55°	21	34.5	10	5	10	MK 42 ER	0.45

Claw Couplings

US-Execution with bore for safety-clips

New!

- Robust couplings of malleable iron, US-execution, zinc plated and yellow passivated (free of chrome VI)
- 100 % couple test and sight control
- with oil-resistant rubber ring GOOR
- To be secured against accidental opening through safety-clips DIN 11024
- US-universal coupling, widely spread system for compressed air in construction and industry



Max. Working Pressure	Temperature	Material	Medium	Claw Distance	Mat. Seal	Thread	⊕
PN 10 bar	-40°C – +95°C	malleable iron	compressed air	41 mm	Perbunan	NPT	10

US-Hose Claw Couplings with safety collar

Hose i.D.	DN	b	h	Weight/pc. g	Type No.	Euro
3/8" = 10 mm	6	62	75	162	SKA 11*	6.20
1/2" = 13 mm	9	62	88	182	SKA 13	3.34
3/4" = 19 mm	14	62	105	244	SKA 19	3.68
1" = 25 mm	20	62	107	286	SKA 25	4.40

For US-hose clamps (⊕ catalogue page 48)

* SKA 11 two parts with thread stem of steel

US-Female Claw Couplings

Thread	DN	b	h	⊕Hexagon	Weight/pc. g	Type No.	Euro
3/8"NPT	15	62	57	27	187	KIA 38	3.95
1/2"NPT	18	62	57	27	181	KIA 12	3.68
3/4"NPT	20	62	57	36	201	KIA 34	3.61
1"NPT	20	62	56	42	218	KIA 10	4.11

On request also available with thread acc. ISO 228 against surcharge.

US-Male Claw Couplings

Thread	DN	b	h	⊕Hexagon	Weight/pc. g	Type No.	Euro
3/8"NPT	9	62	64	29	180	KAA 38	4.51
1/2"NPT	12	62	64	29	190	KAA 12	4.11
3/4"NPT	17	62	70	34	224	KAA 34	4.01
1"NPT	20	62	72	38	260	KAA 10	4.95

On request also available with thread acc. ISO 228 against surcharge.

US-Blank End

Execution	b	h	Weight/pc. g	Type No.	Euro
without chain	62	55	215	UDM	4.68

Original Rubber Ring

Resistance Temp.°C	Medium	Material	Colour	Shore h.	A	⊕i	⊕a	h	Weight/pc. g	⊕	Type No.	Euro
Oil -40 / +95	compr. air	Perbunan	black	50°	20	34	10,5	6	100	GOOR		0.33

Universal Safety Clips DIN 11024

Material	Wire ⊕	b	h	Weight/pc. g	⊕	Type No.	Euro
Steel zinc plated	3 mm	63	27	10	50	USC-1	0.35

US-MODY-Hose Claw Couplings with safety collar

Hose i.D.	DN	b	h	⊕safety collar	Weight/pc. g	⊕	Type No.	Euro
3/8" = 10 mm	6.5	62	111	21	320	5	SSC 10	14.14
1/2" = 13 mm	10	62	118	24	360	5	SSC 13	14.14
3/4" = 19 mm	15	62	120	34	385	5	SSC 19	14.14
1" = 25 mm	18	62	120	39	420	5	SSC 25	14.14

For US-hose clamps (⊕ catalogue page 48); on request also available as thread execution.

Original MODY-Rubber Rings SGOR and SDOR (⊕ catalogue page 25)

